

Schnittansicht A-A

Schnittansicht B-B

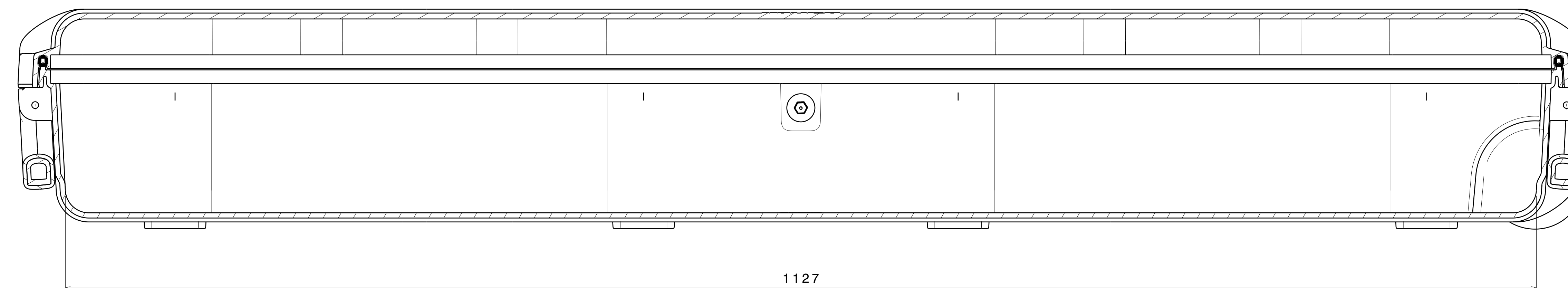

-A- Zeichnung erstellt		23.03.2018	Michael Perle
Zeichner	Zeichnungs-Nr.	Modell-Nr.	Material
AM			1:2
Skizze		Skizzen-Nr.	
pp			
Bezeichnung		ZSB Schutzkoffer 12416	
Titel		Schutzkoffer	
Änderungen an dieser CAD		Änderungs-Nr.	
		12416	

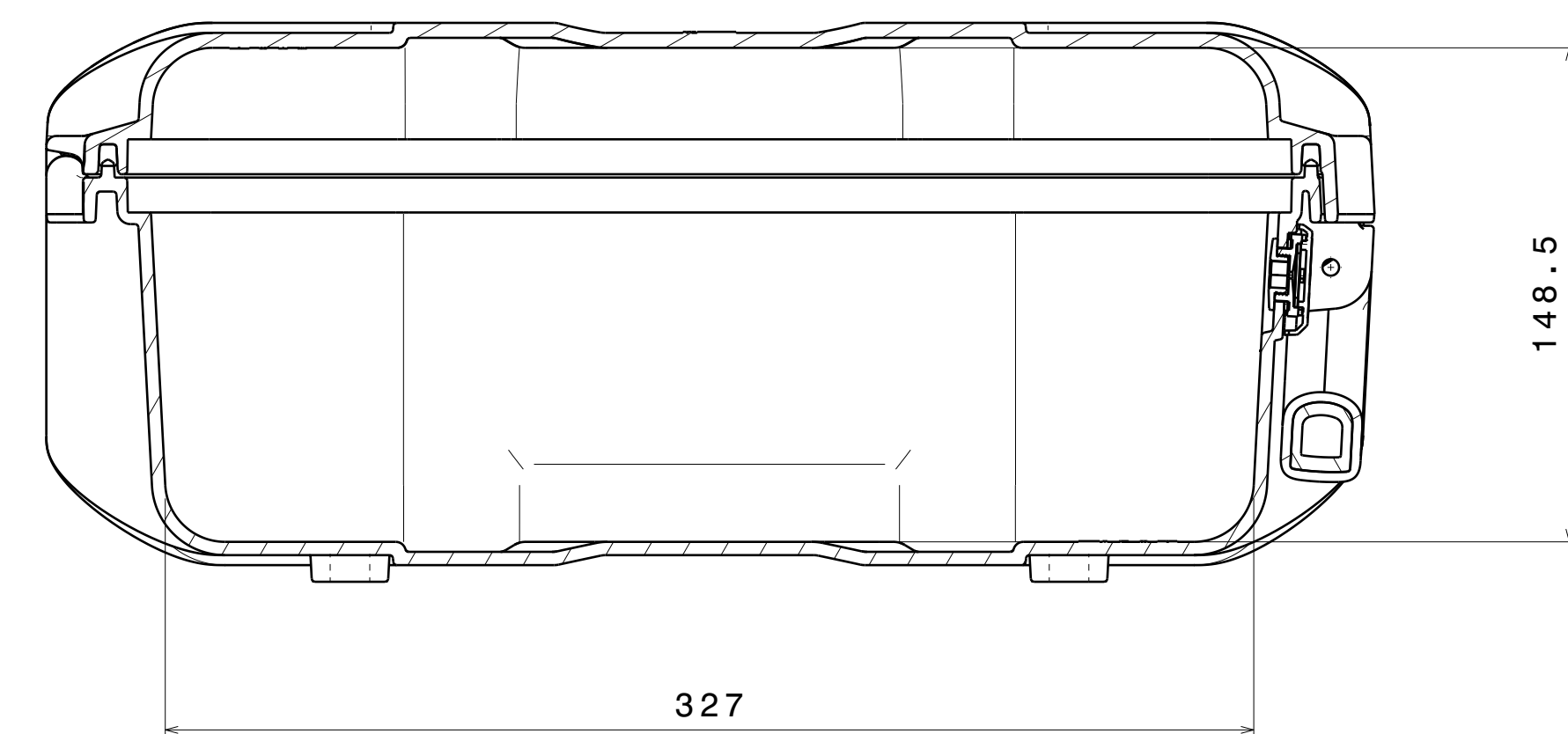

AUER
TECHNOLOGIEPARK
AM KROIT 25/27
D-83123 AMERANG

Zusatz-Nr. 12416
CP 12416