

Schnitt C-C

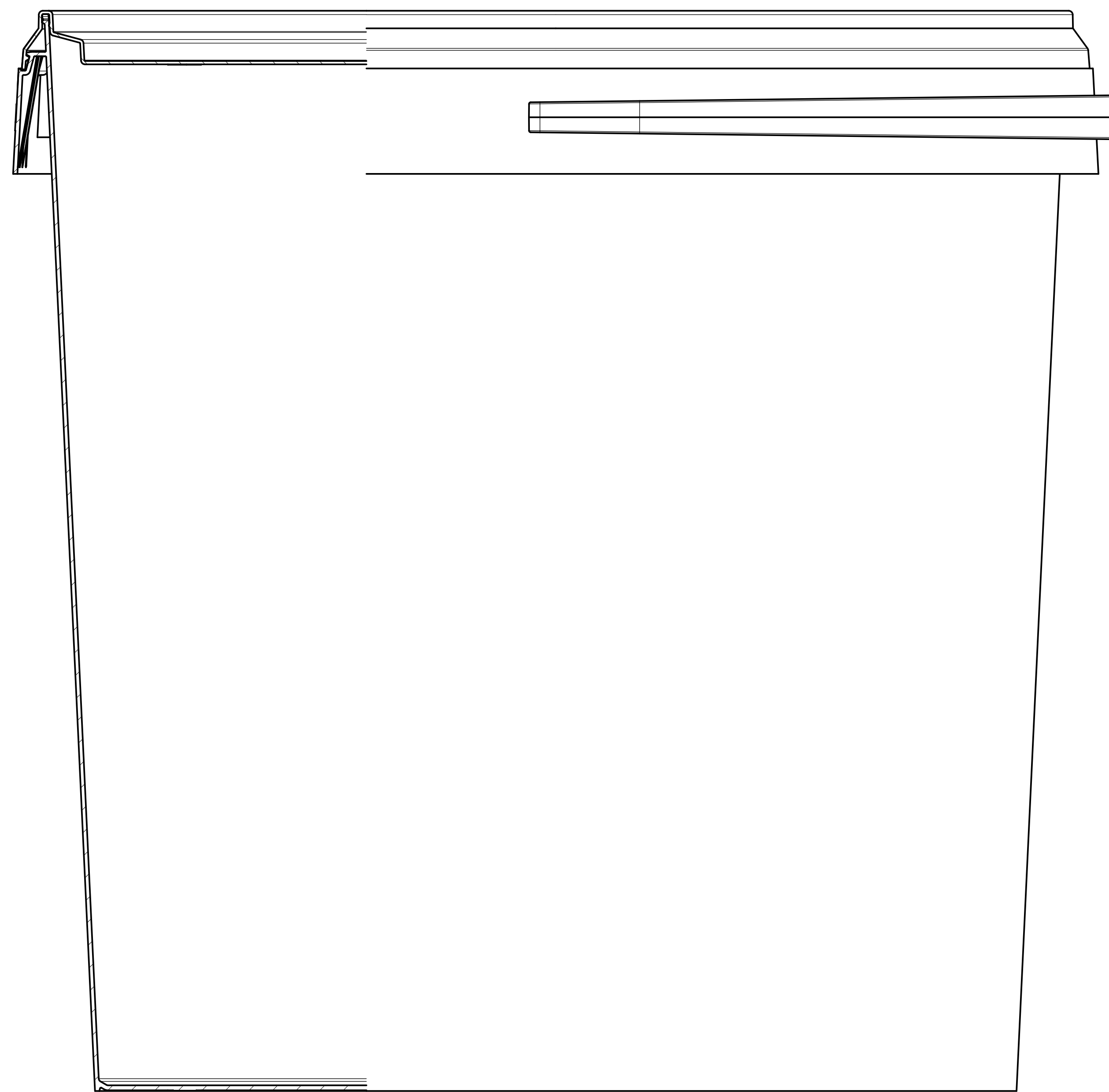

Schnitt AA-AA

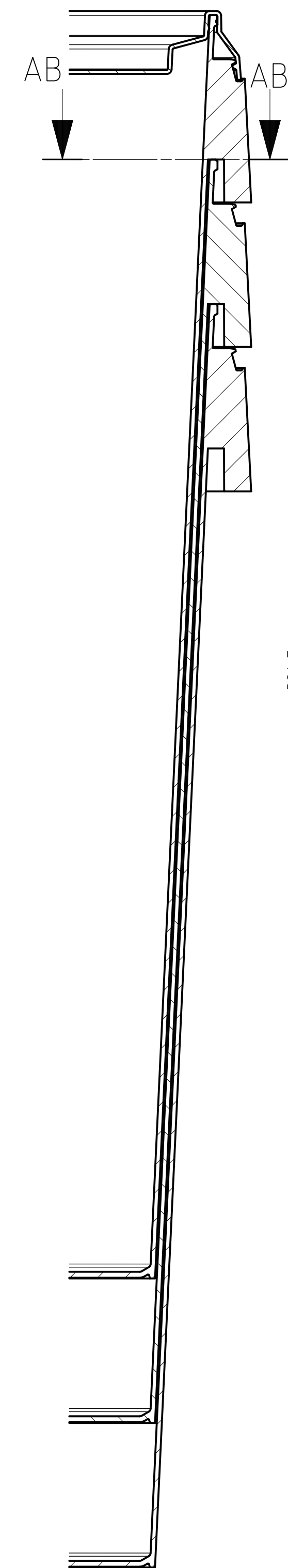

Schnitt A-A

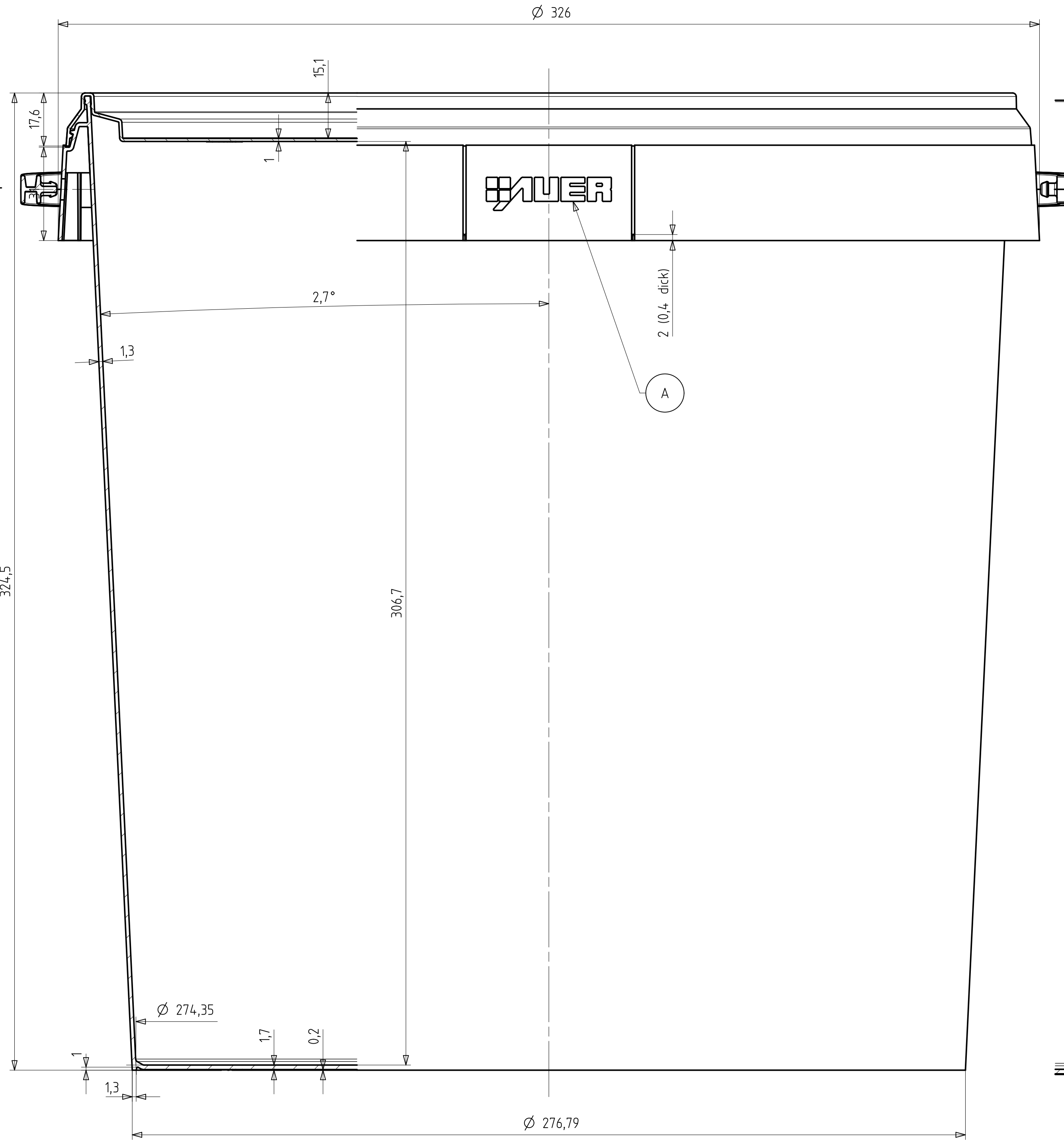

Schnitt B-B

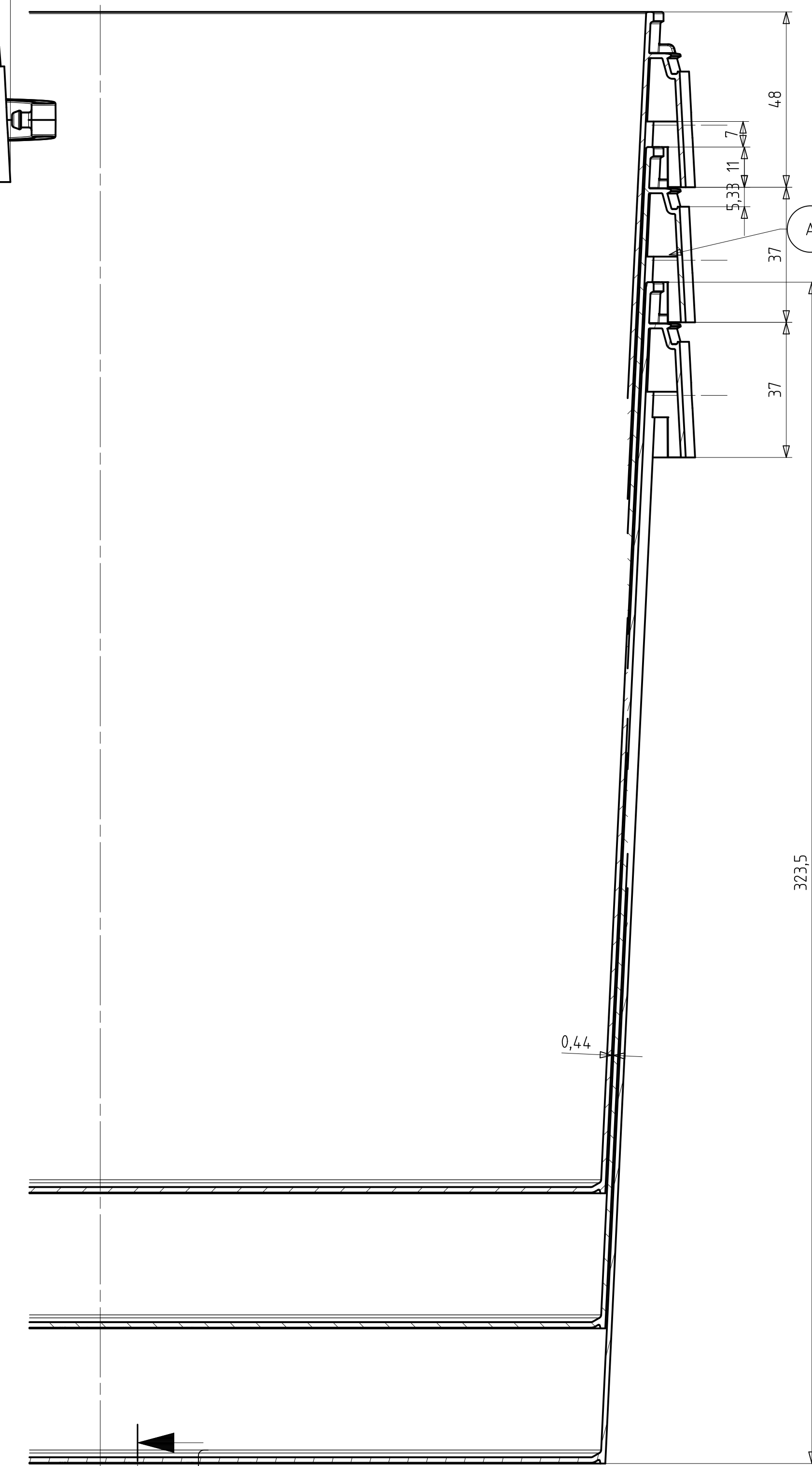

Ansicht Deckel von unten

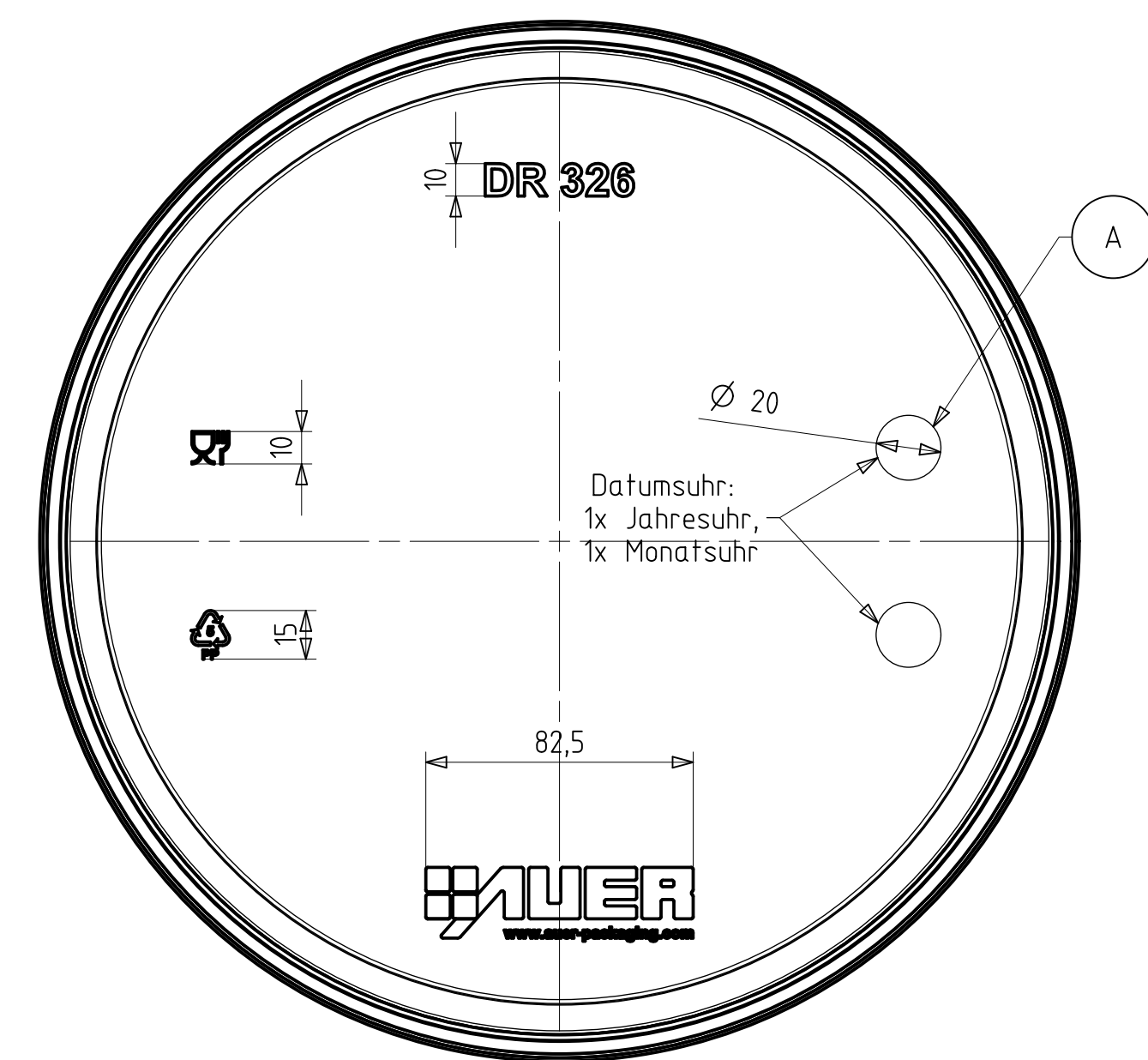

Schnitt AB-AB

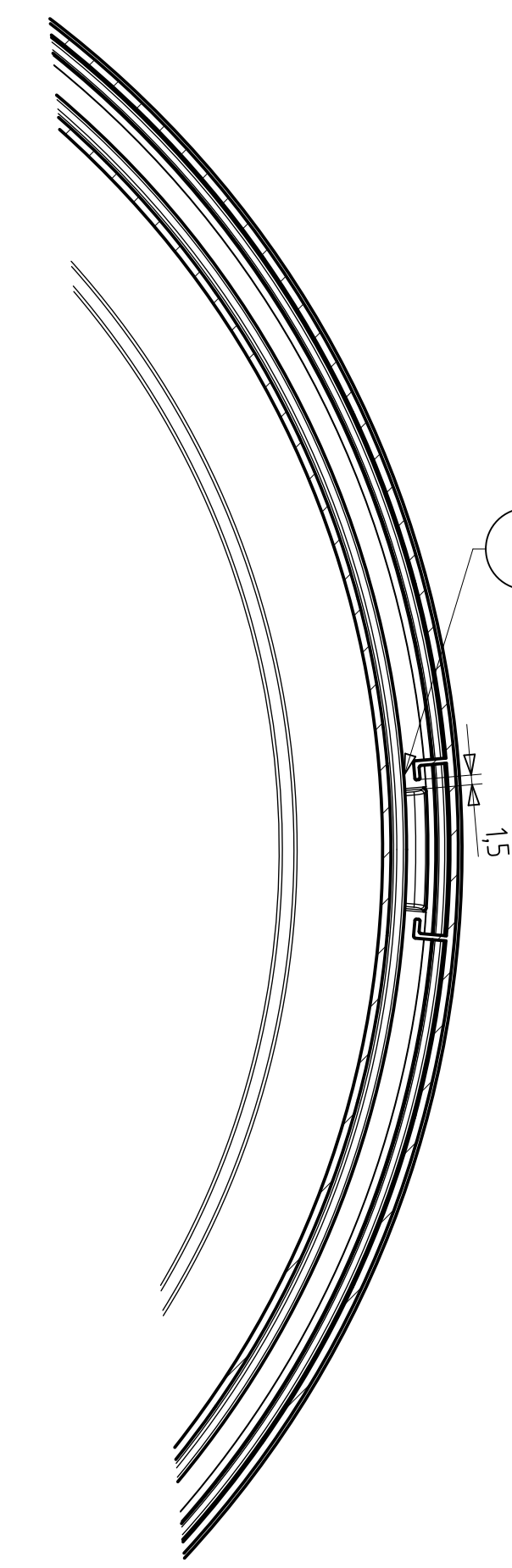

Ansicht von oben Eimer mit Deckel

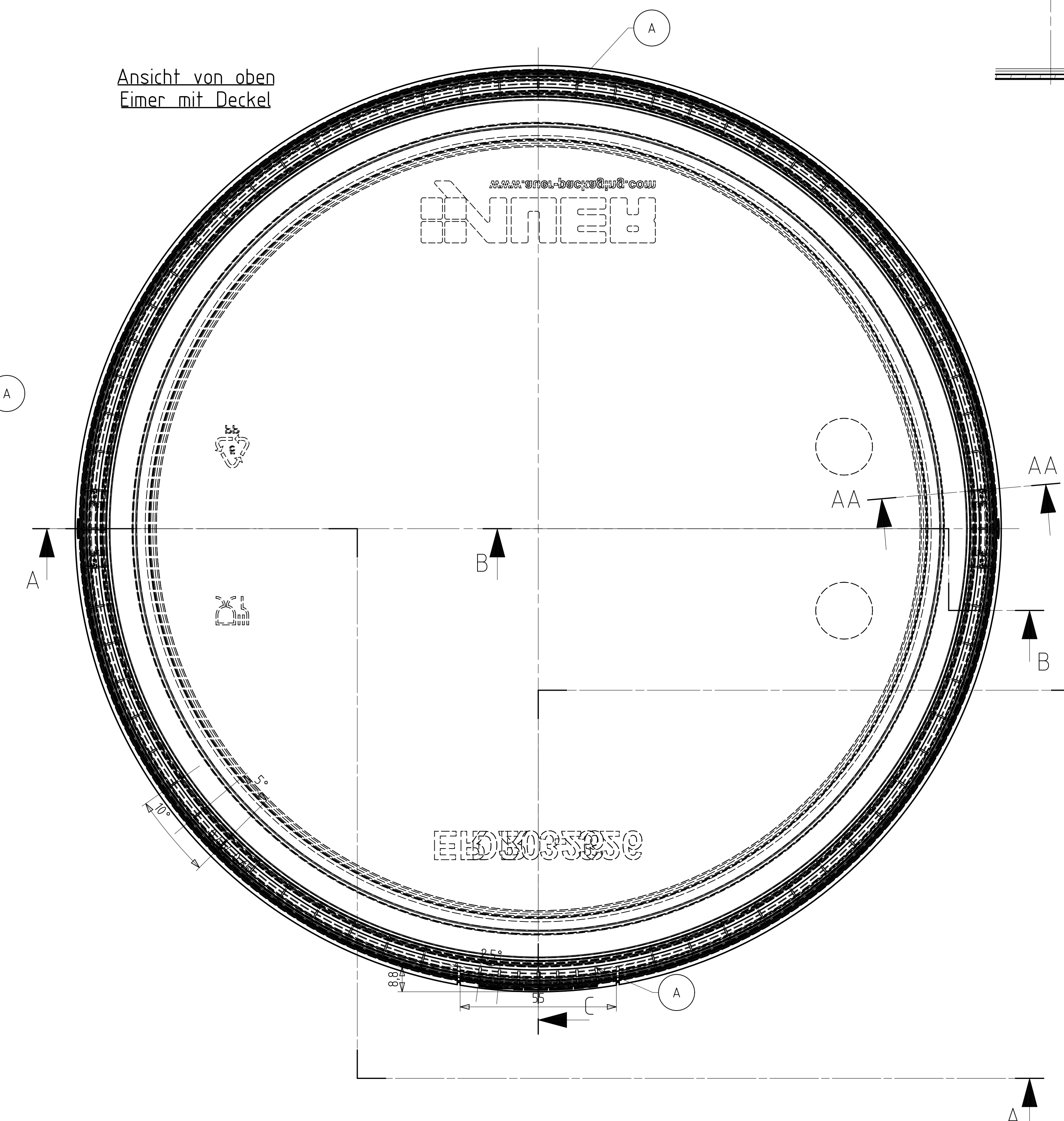

Ansicht Eimer von unten

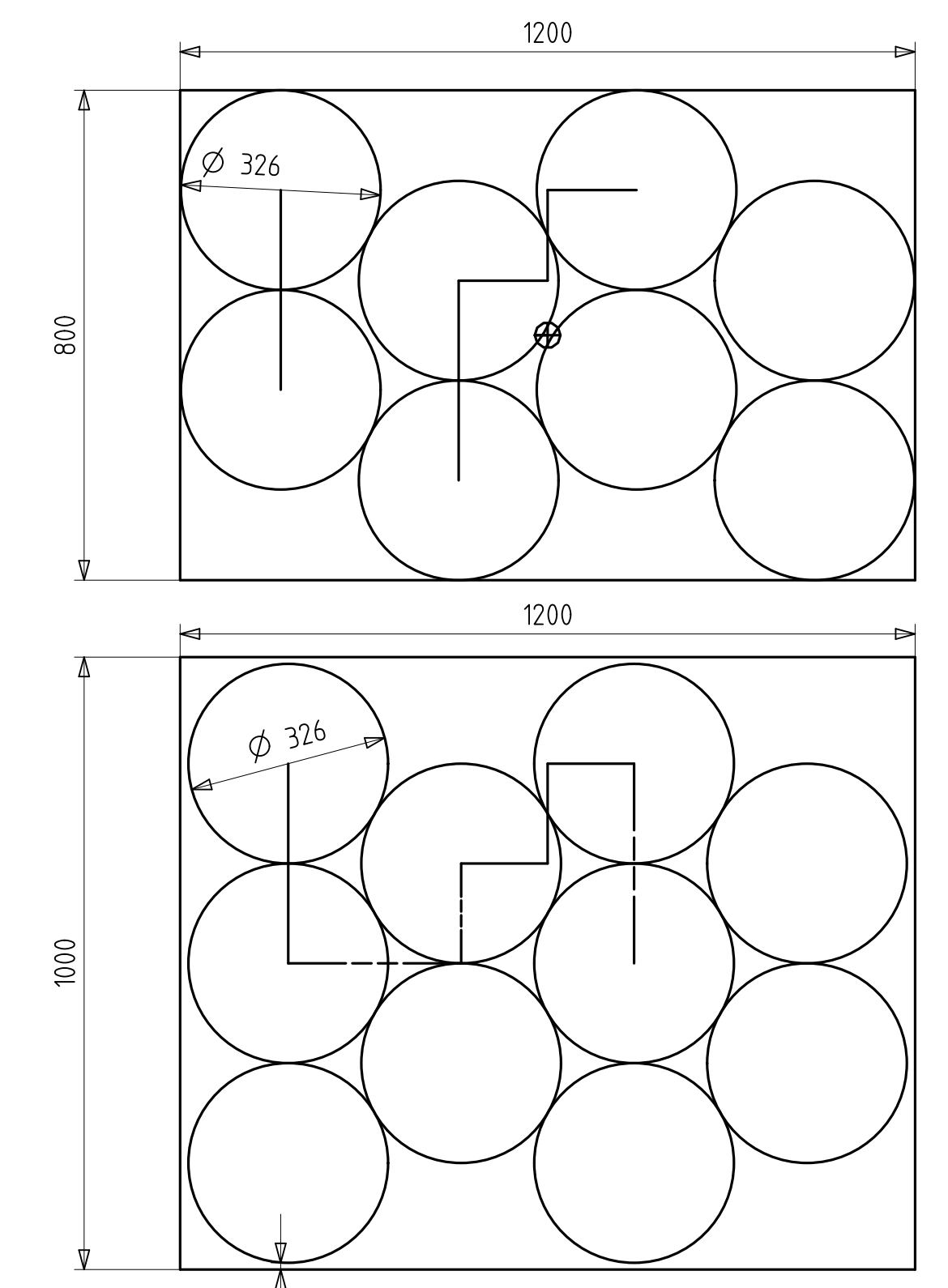
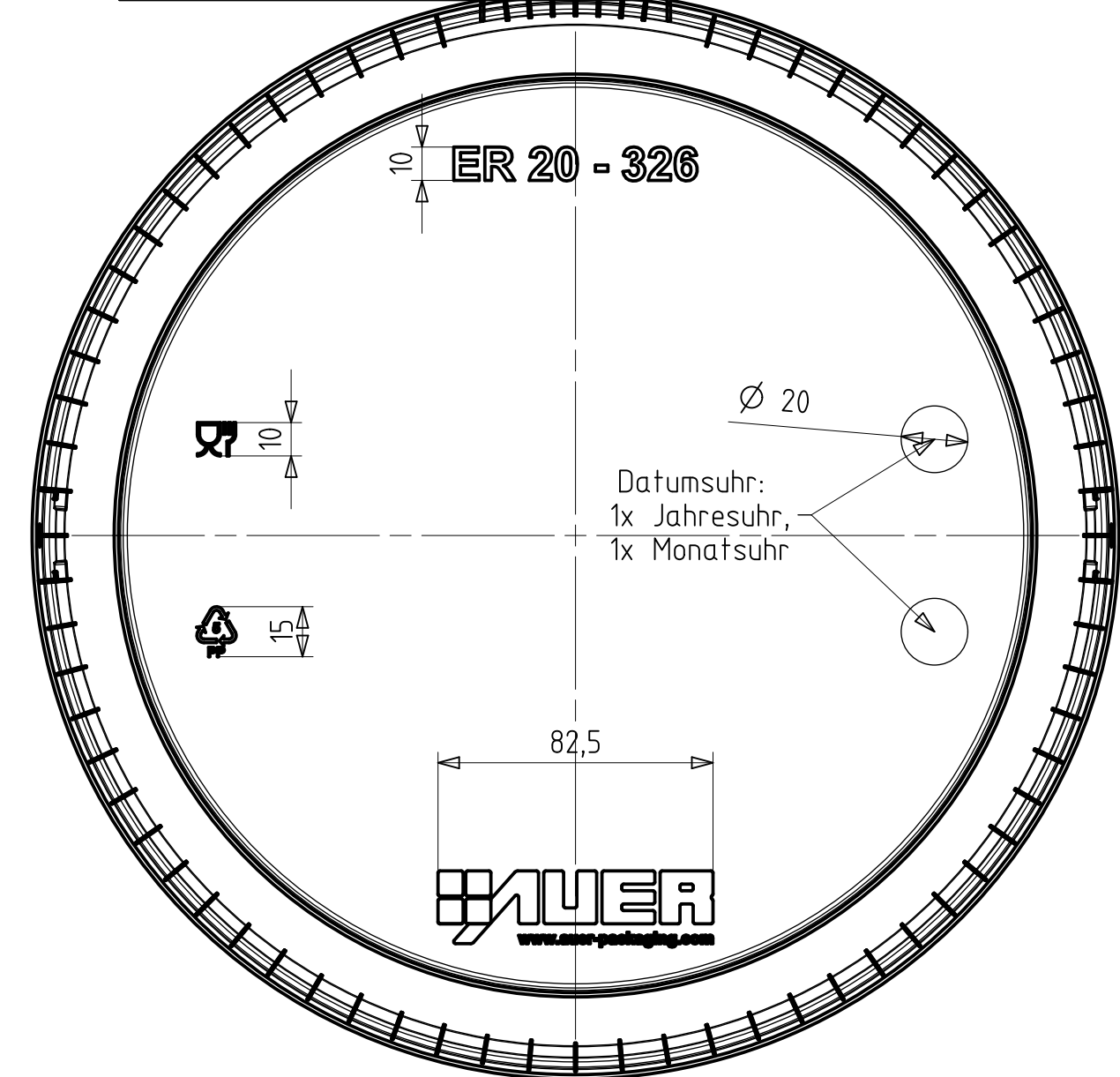

polierte Fläche Eimer: 75,8 dm<sup>2</sup>  
 polierte Fläche Deckel: 20,7 dm<sup>2</sup>  
 Volumen Eimer bis Deckelunterkante: 20,00dm<sup>3</sup>  
 Volumen Eimer bis Eimeroberkante: 21,20dm<sup>3</sup>  
 Artikelvolumen Eimer: 539,10cm<sup>3</sup>  
 Artikelvolumen Deckel: 105,88cm<sup>3</sup>

<b>AUER Packaging GmbH</b> Am Krug 25/27 D-43129 Akenburg		Maßstab: <b>F:1</b> 2013 1010 + 2013 1020	
C: Lich, Rose, Altmann B: Steg, Rille, Wand A: ...	Datum: 13.11.2014 MS 02.10.2014 MS 02.05.2014 MS	Name: M.S. Bearb: ... Gepr: ... Norm: ...	2013 1010 + 2013 1020 <b>Eimer rund 20l</b> + Deckel rund 326